

## 1999 Montero Sport 3.5/3.0L A/T PCM to 1997 Montero Sport 3.0L M/T ECM Harness Pin-Out Conversion Table

Pin-outs were taken directly from the official Mitsubishi™ factory service manuals and as such may contain errors if the service manual documentation is in error. Not all pin-outs may be listed in the tables below. Note that these pin-outs are untested and use of these tables may result in vehicle component damage. As such, the user of this documentation accepts all liability and may not hold the distributor of this document liable for any damages that may occur. Do not attempt to use these tables without confirming that the pin-outs are correct!

### 1997 M/T ECM FED MD338139/MD349089 (GREEN 76-pin)



### 1999 A/T PCM FED MD357516/MD364531 (BLACK 119-pin)



7FU2459

### 1999 A/T PCM -> 1997 M/T Harness

BLACK (male)	Lead <sup>4</sup>	AWG <sup>3</sup>	Description	GREEN (female)	Lead	?CM I/O	NOTES
1		16	No. 1 fuel injector	1			
9		16	No. 2 fuel injector	14			
24		16	No. 3 fuel injector	2			
2		16	No. 4 fuel injector	15			
10		16	No. 5 fuel injector	3			
25		16	No. 6 fuel injector	16			
3			Heated oxygen sensor heater (front) FED	34			
6		18	EGR solenoid FED	6			
11			Ignition power transistor unit A	10			
12			Ignition power transistor unit B	23			
13			Ignition power transistor unit C	11			
14			Stepper motor coil <A1>	4			
28			Stepper motor coil <A2>	17			
15			Stepper motor coil <B1>	5			
29			Stepper motor coil <B2>	18			
34		18	Evaporative emission purge solenoid	32			
18	FLYLD		Condenser fan relay	none		input	<a href="#">B+ votage applied to pin 18 from condenser fan motor relay; when PCM switches on its power transistor, condenser fan motor relay coil is energized, causing current to flow in the circuit</a>
19			Volume air flow sensor reset signal	19			
20			Fuel pump relay module	8			
21			A/C compressor clutch relay	22			
22			Service engine soon/malfunction indicator lamp	36			
26			Heated oxygen sensor heater (rear) FED	42			
35		18	Evaporative emission ventilation solenoid	41			
46			Sensor supplied voltage	81			
45			Crankshaft position sensor	89			
44			Engine coolant temperature sensor	83			
43			Spark check signal (RPM signal?)	51			
41		16	Power supply (ignition switch: "ON")	12			
47		16		25			
48		16	Power supply & ignition switch-IG circuit (body GND #3, #10)	13			
42		16		26			
56			Camshaft position sensor	88			
55			Barometric pressure sensor	85			
52			Power steering pressure switch	37			

49			MFI relay (power supply)		38			
66		16	Backup power supply		80			
65			Volume air flow sensor		90			
64			Intake air temperature sensor		72			
61	FLYLD		A/C switch 2		none	input	<a href="#">B+ (A/C load high) to ≤1v (A/C load low); ≥65.4°F B+ to pin 61 / ≤59°F ≤2v to pin 61; PCM receives signal from A/C automatic compressor-ECU (pin 19) and determines idle-up speed according to high/low air conditioning load</a>	
59		16	Ignition switch-ST GND (body GND #3)		91			GND for M/T conversion
58		16	Ignition switch-ST		71			
71			Heated oxygen sensor (front) FED		76			
73			Heated oxygen sensor (rear) FED		79			
78			Throttle position sensor		84			
79			Closed throttle position switch <3.0L Engine>		87			retain the 3.0L throttle body, TPS, IAC, etc.
80			Vehicle speed sensor		86	output		pulse detection
83			A/C switch		45			
85			Data link connector circuit (OBD connector pin 7)		62			data link connector (1)
84			Data link connector circuit (OBD connector pin 1)		56			data link connector (1)
57			Volume air flow circuit, Baro Pressure Sensor, IAT Sensor, ECT Sensor, TPS Sensor, O2 Sensor (front), O2 Sensor (rear), Evap Emission Control System Pressure Sensor, Closed throttle position switch, MAP Sensor, Fluid temp sensor <A/T>, Input shaft speed sensor <A/T>, Output shaft speed sensor <A/T> GND		92			
91			Manifold differential pressure sensor		74			
92			Fuel tank differential pressure sensor		77			
98		16	Ignition switch-IG		82			
50	FLYLD		A/T control relay		none	output		<a href="#">B+ to trigger-relay controlling B+ power to pins 77/89 (#9)</a>
75			Auto-cruise signal line system circuit		none	output		B+ auto-cruise control ecu (pin 3) overdrive cancel signal. This pin doesn't need to be wired to anything
77	FLYLD	14	Solenoid valve power supply	1	none	input		<a href="#">B+ applied to pins 77/89 through std 4 terminal relay; relay switched on by pin 50 when IG switch turned on</a>
89	FLYLD	16		1	none			
76	FLYLD	16	Body GND (#3)		none			24" flying lead ring terminal
88	FLYLD	16			none			
97	FLYLD	16			none			
101			Park/Neutral position switch P		none	input		B+ applied to pin 101 when selector lever is in the Park range
102			Park/Neutral position switch D		none	input		B+ applied to pin 102 when selector lever is in the Drive range
103	FLYLD		Input shaft speed sensor		none			<a href="#">.33 - .39 kΩ; insert 350 Ω, .5w resistor; loops back to PCM pin 57</a>
104	FLYLD		Output shaft speed sensor		none			<a href="#">.22 - .28 kΩ; insert 250 Ω, .5w resistor; loops back to PCM pin 57</a>
106	FLYLD		Second solenoid valve	1	none	input		<a href="#">68°F 2.7 - 3.4 Ω - insert appropriate resistor in harness; constant B+ applied to solenoid (pin 106 through terminal 9)</a>
107	FLYLD		Torque converter clutch solenoid valve	1	none	input		<a href="#">68°F 2.7 - 3.4 Ω - insert appropriate resistor in harness; constant B+ applied to solenoid (pin 107 through terminal 10)</a>
108			Park/Neutral position switch R		none	input		B+ applied to pin 108 when selector lever is in the Reverse range
109			Park/Neutral position switch 3		none	input		B+ applied to pin 109 when selector lever is in the 3rd range
110			Park/Neutral position switch L		none	input		B+ applied to pin 110 when selector lever is in the Low range
113	FLYLD		Data link connector circuit (connector pin 26)		none			<a href="#">data link connector (2) C-82 12-pin PCM flash pin 26</a>
114	FLYLD		Data link connector circuit (connector pin 27)		none			<a href="#">data link connector (2) C-82 12-pin INVECS-II pin 27</a>
120	FLYLD		Under drive solenoid valve	1	none	input		<a href="#">68°F 2.7 - 3.4 Ω - insert appropriate resistor in harness; constant B+ applied to solenoid (pin 120 through terminal 9)</a>
121	FLYLD		Park/neutral position switch N / "N" range light system circuit	2	none	input		<a href="#">B+ applied to pin 121 when selector lever is in the Neutral range; bulb resistance ??? Ω - insert appropriate resistor or bulb in harness, tap lead with resistor, attach other end to Body GND (#9)</a>
122			Park/neutral position switch 2		none	input		B+ applied to pin 122 when selector lever is in the 2nd range
123	FLYLD	17	Stoplight switch		none	input		brake depressed, B+ applied to pin 123

124	FLYLD		Fluid temperature sensor		none		output	<a href="#">5v 32°F 16.7 - 20.5 kΩ / 212°F .57 - .69 kΩ; insert 1.1kΩ,1w resistor (176° 1.0 - 1.2 kΩ, 1.7 - 1.9 V); loops back to PCM pin 57</a>
125			Transfer low detection switch		none		output	4L continuity / other than 4L, no continuity, this pin doesn't need to be wired to anything
126			Pattern select switch		none		input	Hold switch, B+ when switch on/no voltage with switch off, this pin doesn't need to be wired to anything
129	FLYLD		Low-reverse solenoid valve	1	none		input	<a href="#">68°F 2.7 - 3.4 Ω - insert appropriate resistor in harness; constant B+ applied to solenoid (pin 129 through terminal 10)</a>
130	FLYLD		Overdrive solenoid valve	1	none		input	<a href="#">68°F 2.7 - 3.4 Ω - insert appropriate resistor in harness; constant B+ applied to solenoid (pin 130 through terminal 9)</a>

1 B+ applied to 77, 89, 106, 107, 120, 129, and 130 from A/T Control Relay

2 wire harness for selector lever in N; apply B+

AWG	mm <sup>2</sup>	
14	2.00	
16	1.25	
17	0.85	
18	0.75	
20	0.50	<i>unless otherwise noted, wire gauge is 20 AWG (0.5 mm<sup>2</sup>)</i>

4 FLYLD = flying lead (12" length unless otherwise noted)

\* confirm in manual

### 2001-2004? A/T PCM -> 1997 M/T Harness

BLACK (male)	Lead	AWG	Description	GREEN (female)	Lead	PCM I/O	NOTES
7			A/T fluid temperature warning light <V4A51> <A/T>	none			
20			A/C compressor clutch relay	22			
21			Fuel pump relay module	8			
50			A/T Control Relay System GND <A/T>	none			
51			Fuel temperature sensor (Fuel temperature sensor circuit)	none			run wire from fuel level/temperature sensor pin 1 <00-04 fuel temperature signal/sensor>
59			Park/neutral position switch <A/T>	91			
60			Fuel gauge unit (Fuel level sensor circuit)	none			tap from fuel gauge circuit <97-04 fuel level signal/sensor pin 2>
75			Auto-cruise signal line system circuit	none			
76			GND	none			
77			A/T Control Relay System (solenoid valve PS) <A/T>	none			
89				none			
88			GND	none			
97				none			
96			Fuel level warning light	none			intercept fuel level warning light signal/sensor pin 1 <97-99>
103			Input shaft speed sensor system <A/T>	none			
104			Output shaft speed sensor system <A/T>	none			
110			Park/Neutral Position Switch System (L) <A/T>	none			
122			Park/Neutral Position Switch System (2) <A/T>	none			
109			Park/Neutral Position Switch System (3) <A/T>	none			
102			Park/Neutral Position Switch System (D) <A/T>	none			
121			Park/Neutral Position Switch System (N) <A/T>	none			
108			Park/Neutral Position Switch System (R) <A/T>	none			
101			Park/Neutral Position Switch System (P) <A/T>	none			

120		Low/Reverse solenoid system valve circuit (underdrive) <A/T>		none			
106		Low/Reverse solenoid system valve circuit (second) <A/T>		none			
130		Low/Reverse solenoid system valve circuit (overdrive) <A/T>		none			
107		Low/Reverse solenoid system valve circuit (torque converter clutch) <A/T>		none			
129		Low/Reverse solenoid system valve circuit (low & reverse) <A/T>		none			
123		Stoplight switch system circuit <A/T>		none			
124		A/T fluid temperature sensor system circuit <A/T>		none			
112		Transfer low detection switch <V4A51> <A/T>		none			
111		Immobilizer/PCM communications line		none			PCM/immobilizer control module must come from same vehicle/additional parts and wiring required

A/T Fluid Temperature Sensor Circuit

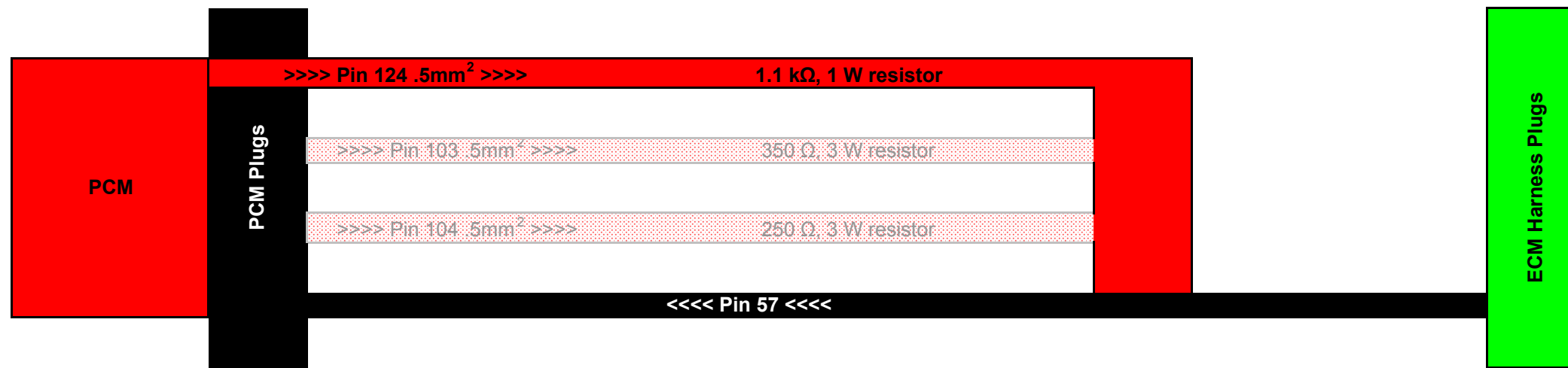

**A/C Switch 2 and Condenser Fan Control Circuit**

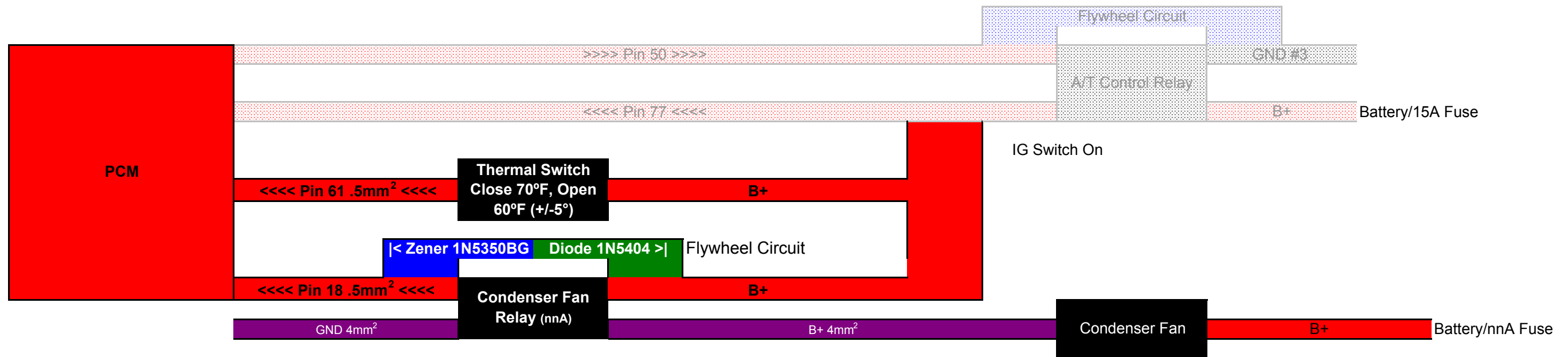

<http://www.senasys.com/shop/products-page/2570-34-sealed/2570f068/>

2570F068 (070 F-563 Close 70°F, Open 60°F (+/-5))  
 2570F068 (090 F-664 Close by 90°F max, Open by 80°F min)



Alternate thermal switch setup

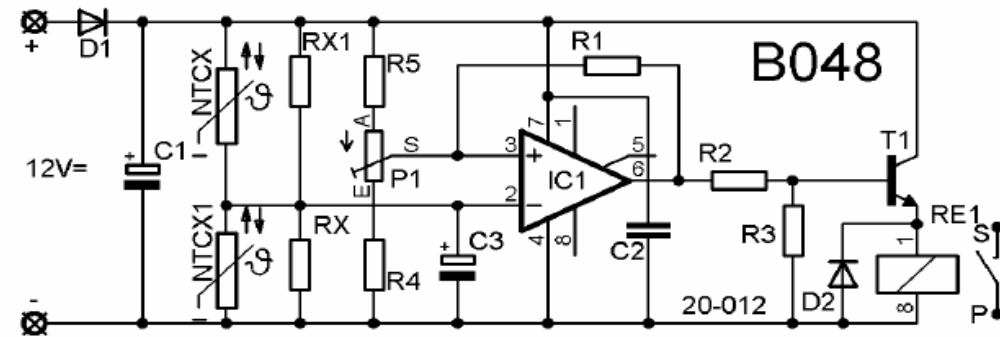
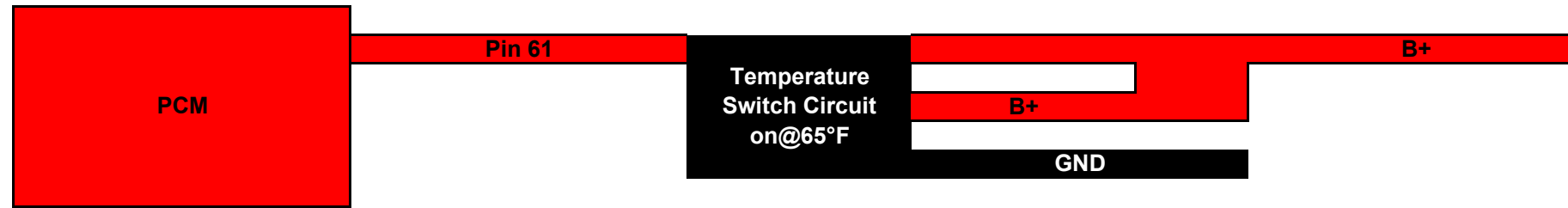

<http://www.kemo-electronic.de/en/Transformer-Dimmer/Switches/Kits/B048-Temperature-switch-12-V-DC.php>

Kemo Electronic

12 V= Temperature switch Kit [B048]

Operating voltage: 12...14V=

Current consumption: approx. 100mA at maximum

Temperature switching range: approx. -30 ... + 150 °C

Relay contact: 1 x ON

Contact capacity relay: max. 25V, 3A

Board dimensions: approx. 54 x 27 mm

# A/T Control Relay Diagram

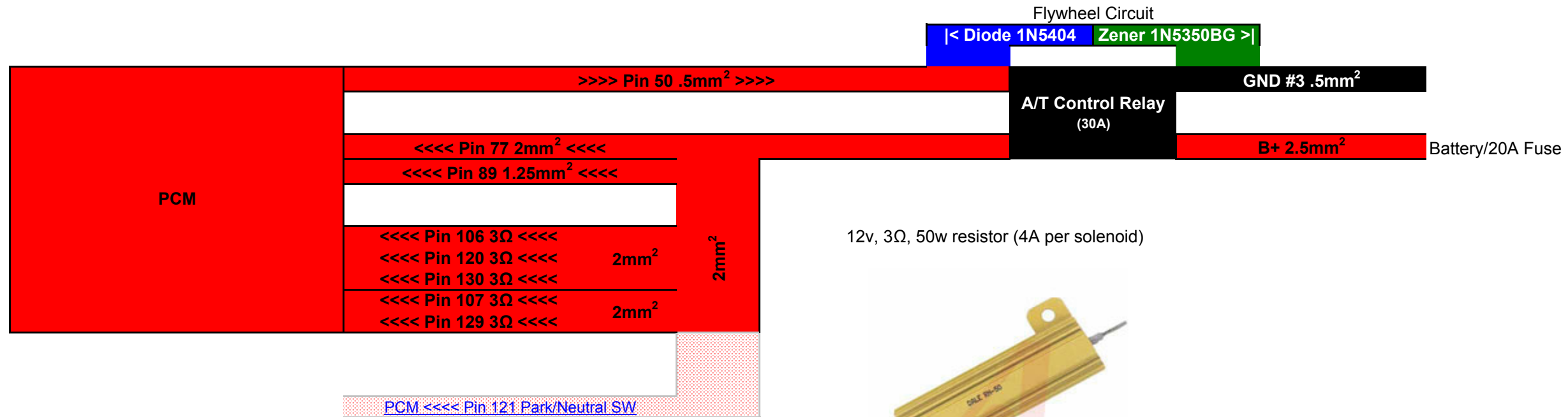

Solenoids:  
 Engine: Idling  
 Gear range: Nst gear, engine idling B+  
 Selector lever position: Park 6-9v

Pin 89, 106, 107, 120, 129, 130 tap off of 77  
 Resistor 106, 120, 130 in paralel  
 Resistor 107, 129 in paralel





**Park/Neutral Position Switch, Position "N"**

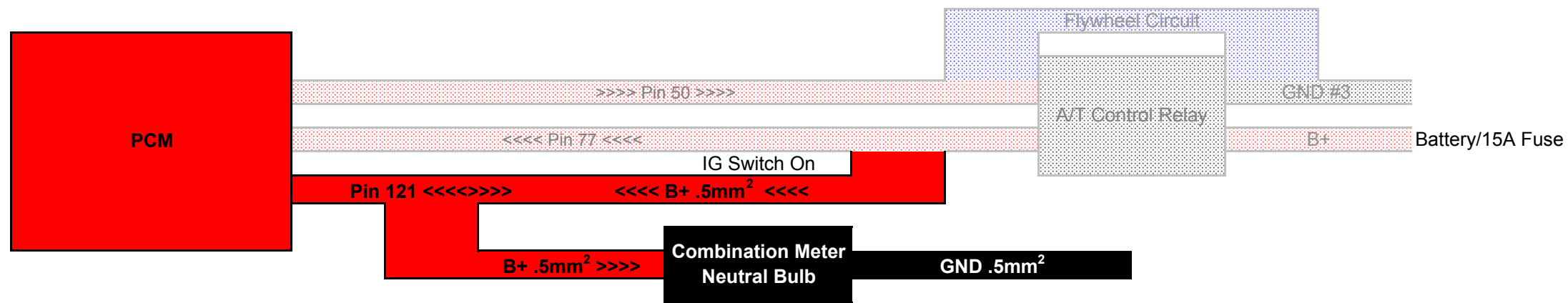

Mitsu '99 Neutral gauge cluster bulb, resistor n Ω, or LED

Wire the PCM so 'transmission' is in constant Neutral

3mm LED with protective diodes and capacitor  
<http://www.richmondcontrols.com/WhiteLED.html>; Kingbright  
 3mm cylindrical LED

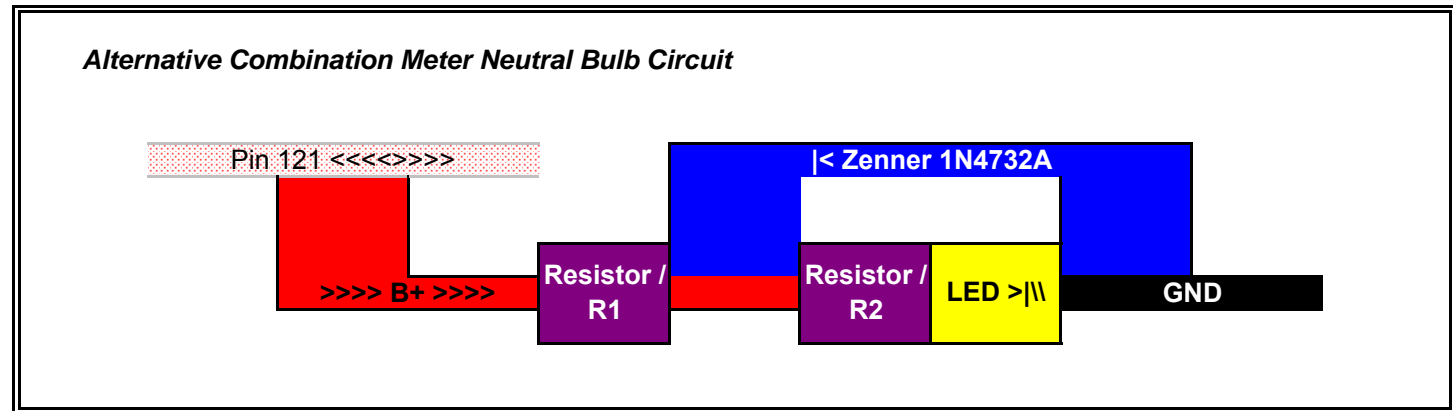

Kingbright 100° Cylindrical LED 70062945, 70062946, 70062947  
 r1=300 ohm, .5w, Tol ±1%

d2=green, 2.2v, 25ma  
 r2=100 ohm, .5w, Tol ±1%

d2=red, 2v, 30ma  
 r2=100 ohm, .5w, Tol ±1%

d2=yellow, 2.1v, 30ma  
 r2=100 ohm, .5w, Tol ±1%

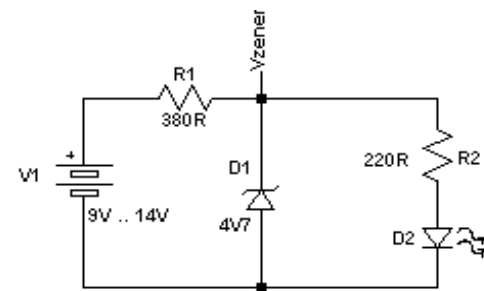

Example of a circuitry that maintains a constant voltage across the LED as battery discharges to maintain constant brightness of LED.  
<http://www.mayothi.com/diodes.html>

On-Board Diagnostics (OBD) Flash

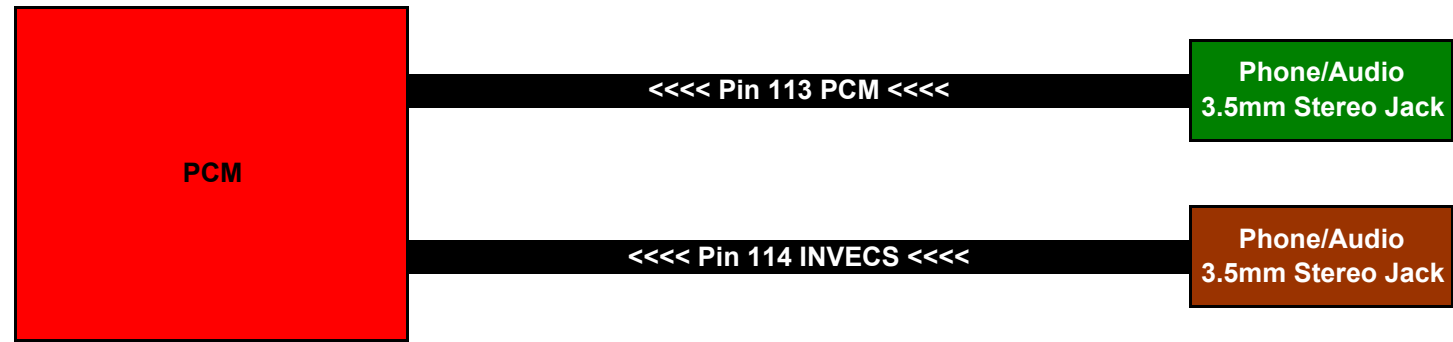

### Transmission Input/Output Speed Sensors

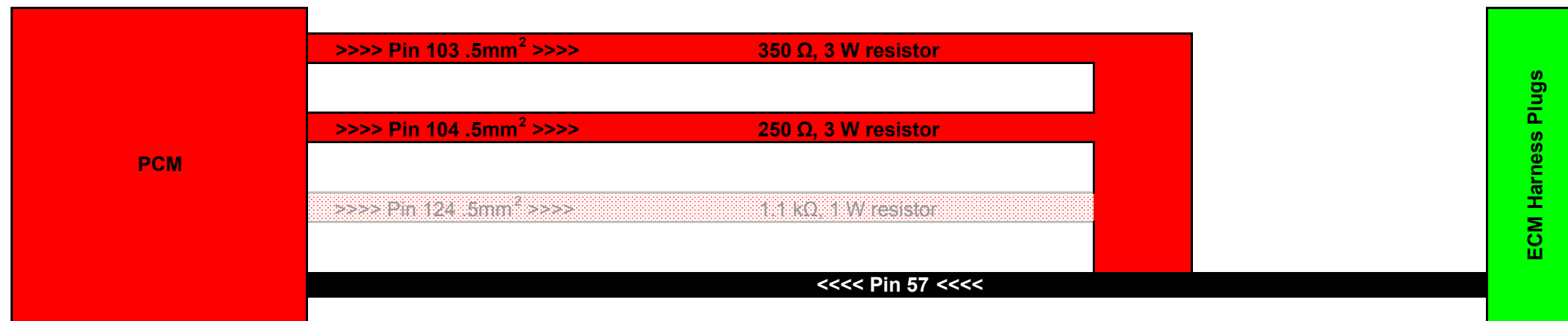

output shaft speed\* x current transmission gear ratio = input shaft speed\*

\* speed = number of pulses

1997 Mitsubishi Montero Sport 3.0L ECM M/T & A/T



1999 Mitsubishi Montero Sport 3.5L PCM A/T



**Wire Gauge Conversion Table**

No code indicates 0.5 mm2

American Wire Gauge (AWG)	Diameter (in)	Diameter (mm)	Cross Sectional Area (mm2)
0	0.46	11.68	107.16
0	0.4096	10.4	84.97
0	0.3648	9.27	67.4
0	0.3249	8.25	53.46
1	0.2893	7.35	42.39
2	0.2576	6.54	33.61
3	0.2294	5.83	26.65
4	0.2043	5.19	21.14
5	0.1819	4.62	16.76
6	0.162	4.11	13.29
7	0.1443	3.67	10.55
8	0.1285	3.26	8.36
9	0.1144	2.91	6.63
10	0.1019	2.59	5.26
11	0.0907	2.3	4.17
12	0.0808	2.05	3.31
13	0.072	1.83	2.63
14	0.0641	1.63	2.08
15	0.0571	1.45	1.65
16	0.0508	1.29	1.31
17	0.0453	1.15	1.04
18	0.0403	1.02	0.82
19	0.0359	0.91	0.65
20	0.032	0.81	0.52
21	0.0285	0.72	0.41
22	0.0254	0.65	0.33
23	0.0226	0.57	0.26
24	0.0201	0.51	0.2
25	0.0179	0.45	0.16
26	0.0159	0.4	0.13

AWG	mm2	AWG	mm2	AWG	mm2	AWG	mm2
30	0.05	18	0.75	6	16	4/0	120
28	0.08	17	1	4	25	300MCM	150
26	0.14	16	1.5	2	35	350MCM	185
24	0.25	14	2.5	1	50	500MCM	240
22	0.34	12	4	1/0	55	600MCM	300
21	0.38	10	6	2/0	70	750MCM	400
20	0.5	8	10	3/0	95	1000MCM	500